



Plains Rifle Forend Cap, wax cast:

Wax cast, to exactly match our buttplates and triggerguards. The 13/16, 7/8 and 15/16" forend caps are shaped for a 3/8" diameter ramrod with a .22" web thickness.

- #FC-PA-13-B forend cap, 13/16", cast brass **only \$14.29**
- #FC-PA-13-I forend cap, 13/16", cast steel **only \$10.99**
- #FC-PA-13-S forend cap, 13/16", cast nickel silver **only \$13.99**
- #FC-PA-14-B forend cap, 7/8", wax cast brass **only \$14.29**
- #FC-PA-14-I forend cap, 7/8", wax cast steel **only \$10.99**
- #FC-PA-14-S forend cap, 7/8", cast nickel silver **only \$13.99**
- #FC-PA-15-B forend cap, 15/16", wax cast brass **only \$14.29**
- #FC-PA-15-I forend cap, 15/16", wax cast steel **only \$10.99**
- #FC-PA-15-S forend cap, 15/16", cast nickel silver **only \$13.99**

The 1" forend caps are shaped for a 7/16" diameter ramrod with a .22" web thickness.

- #FC-PA-16-B forend cap, 1", wax cast brass **only \$14.29**
- #FC-PA-16-I forend cap, 1", wax cast steel **only \$10.99**
- #FC-PA-16-S forend cap, 1", cast nickel silver **only \$13.99**



Plains Rifle Forend Cap for 1-1/6" and 1-1/8" , wax cast:

Wax cast, to exactly match our buttplates and triggerguards. The 1-1/16 and 1-1/8" forend caps are shaped for a 7/16" diameter ramrod with a .22" web thickness. Made for our Jim Bridger Hawken rifle.

- #FC-PA-17-B forend cap, 1-1/16", wax cast brass **only \$14.29**
- #FC-PA-17-I forend cap, 1-1/16", wax cast steel **only \$10.99**
- #FC-PA-17-S forend cap, 1-1/16", cast nickel silver **only \$13.50**
- #FC-PA-18-B forend cap, 1-1/8", wax cast brass **only \$14.29**
- #FC-PA-18-I forend cap, 1-1/8", wax cast steel **only \$10.99**
- #FC-PA-18-S forend cap, 1-1/8", cast nickel silver **only \$13.50**

If you need to ADD or CHANGE your order, re-use our on-line shopping cart, within one hour.



Polished Forend Cap:

For a halfstock rifle with 1" octagon barrel. Retained by a rivet or screw, from inside the barrel channel into the rod groove.

- #FC-TC-16-B forend cap, 1", polished brass **only \$ 9.29**
- #FC-TC-16-I forend cap, 1", polished iron **only \$ 9.29**
- #FC-TC-16-S forend cap, 1", polished nickel **only \$11.50**
- #Screw-5-40-F forend cap retaining screw, 5-40 **only \$.30**

Hawken Rifle plan, halfstock & fullstock:

This large plan drawing details construction of both the classic late Hawken halfstock rifle, and the earlier fullstock Hawken rifle. Both guns are shown on the same plans, in separate views, to illustrate the similarities. You may wish to combine elements of each in your work. These plans show you the inside details. We stock the parts needed to build either style of Hawken rifle.

- #Plan-Hawken Hawken rifle plan **only \$ 6.50**

J & S Hawken Pistol plan:

Replicate the very rare Hawken pistol. Our plan drawings show the required parts, assembly suggestions, and popular variations.

- #Plan-HP Hawken pistol plan **only \$ 3.50**



English Forend Cap, wax cast:

A bit more elegant, sleek, and graceful than our Plains rifle forend caps, this forend cap is ideal for an English Sporting rifle, or a refined American target rifle. Brass or steel, 1" or 1-1/16" octagon.

- #FC-ENG-16-B forend cap, 1", wax cast brass **only \$14.99**
- #FC-ENG-16-I forend cap, 1", wax cast steel **only \$10.99**
- #FC-ENG-17-B forend cap, 1-1/16", wax cast brass **only \$14.99**
- #FC-ENG-17-I forend cap, 1-1/16", wax cast steel **only \$10.99**



Hawken Pistol Forend Cap:

A short forend cap, made for use on a 15/16" octagon barrel, especially on a halfstock pistol, such as our Hawken pistol.

- #FC-HP-15-B short, 15/16", wax cast brass **only \$14.99**
- #FC-HP-15-I short, 15/16", wax cast steel **only \$10.99**



Unplated #5-40 flat head retaining screw, for use in mounting the forend cap. Sold individually.

- #Screw-5-40-F steel machine screw, 5-40 thread **only \$.30**
- #Tap-5-40-T taper tap, 5-40 thread, carbon steel **only \$2.99**
- #Drill-38 tap drill for 5-40 thread, .1015" **only \$1.99**

- #Pewter 1 lb. pewter ingot **only \$5.99**



©2012, Track of the Wolf, Inc.

shown actual size

Made in the U.S.A.

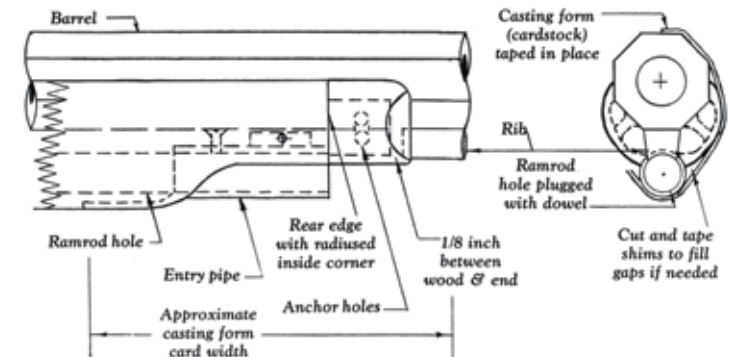

Pewter ingot, for casting a forend cap in place:

Original rifles often used "pewter" muzzle caps. Pour your own pewter forend cap, and finish it in place.

Our one pound ingot of forend cap alloy will make three or more Hawken forend caps. Each ingot includes illustrated instructions for melting and pouring.

- #Pewter pewter ingot, with instructions, 1 lb. **only \$ 5.99**